



Calvi Network **Meeting 2014**

MILAN / **21st / 22nd / 23rd October**

LIFT-UP

PALAZZO DELLE STELLINE
MILAN, ITALY





LIFT-UP

Calvi Network **Meeting 2014**

MILAN / 21st / 22nd / 23rd October

Innovation in a totally integrated supply chain

The annual meeting on the different activities of the CALVI Group, to which the mast division with Lift-Tek Elecar belongs to, has also taken place this year. The main focus has been the product innovation as well as the research of solutions with particular prominence to the innovation within the Group. Calvi Holding in fact controls the whole supply chain starting from the steel production of the mast profiles by Hoesch and Siderval up to the lift mast production, in which design, on-going research and development of new solutions represent the winning move.

The “tail end” of the supply chain: The lift mast

And yet through the engineering of the supply chain we are able to introduce
concepts such as :

Flexibility, design, new solutions and INNOVATION

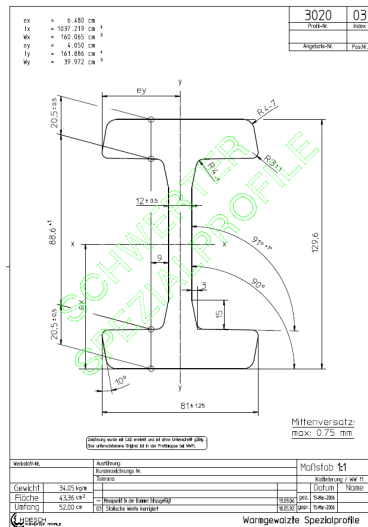

Engineering

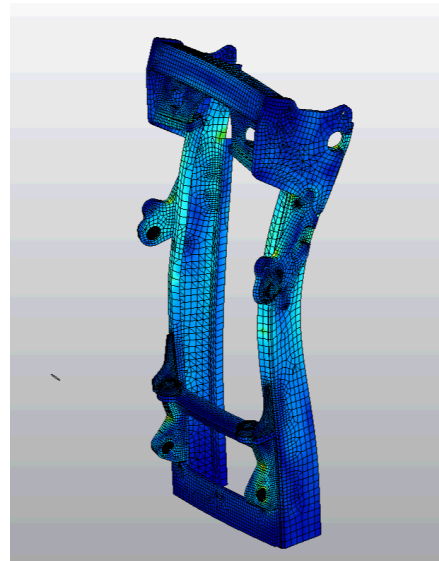

Design

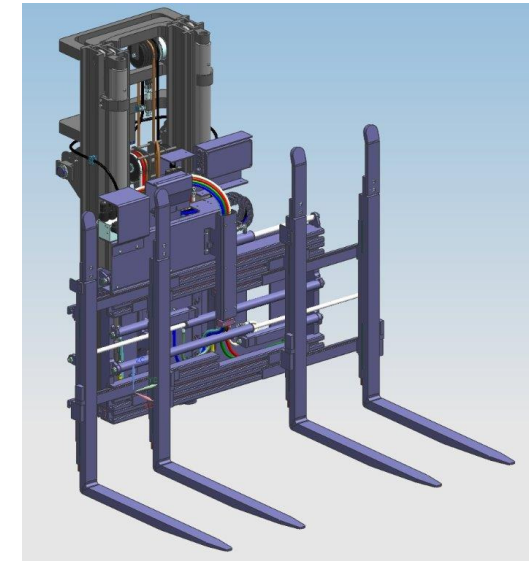

R&D working hours dedicated by Lift-Tek Elecar to INNOVATION



Take a look at the increasingly growing number of hours, which R&D have dedicated to innovation since 2008. While in the period prior to the financial crisis we had a stable market, nowadays the ongoing research of new solutions can only take place through new design development.